

Model CDD-R Series Walkie Pallet stacker

● OPERATION MANAUL



Foshan Panda Hardware Co.,Ltd

Warning!

The operator should strictly follow ISO 3691:1980 *Safety Specification for Industrial Vehicles* and it is prohibited for untrained people to operate the truck.

1 Contour diagram

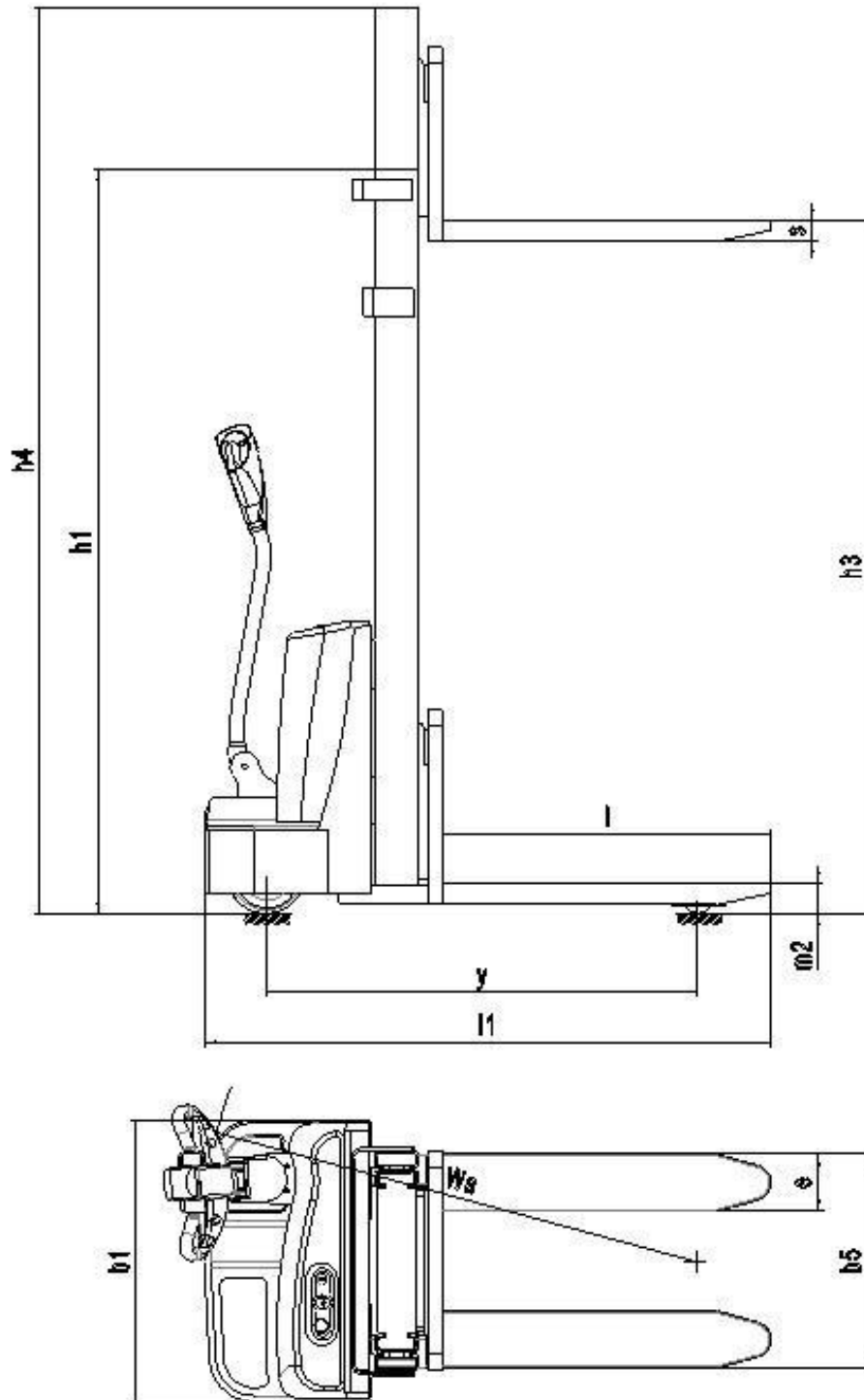

Figure 1-1

2 Main technical parameters

1.1	Model		CDD-10R CDD-12R CDD-15R
1.2	Drive type		Battery
1.3	Operation type		Walkie type
1.4	Rated capacity	Q(kg)	1000/1200/1500
1.5	Load center	c(mm)	600
2.1	Service weight	kg	553
3.1	Wheels material		Polyurethane
4.1	Max. lift height	h3(mm)	1600/2500/3000
4.2	Lowered mast height	h1(mm)	2080/1830/2080
4.3	Extended mast height	h4(mm)	2050/2950/3450
4.2	Lowered fork height	h13(mm)	85
4.3	Overall length	l1(mm)	1750
4.4	Overall width	b1(mm)	790
4.5	Fork size	S/e/l(mm)	60/142/1070
4.6	Fork width	b5(mm)	570/660
4.7	Ground clearance	m2(mm)	30
4.8	Turning radius	Wa(mm)	1390
5.1	Traveling speed, laden/unload	Km/h	3.5/4
5.2	Lifting speed, laden/unload	m/s	0.1/0.2
5.3	Descending speed, laden/unload	m/s	0.12/0-0.1
5.4	Max. gradient, laden/unload	%	3/10
5.5	Brake		Electromagnetic brake
6.1	Drive motor power	kW	0.75
6.2	Lift motor power	kW	2
6.3	Battery voltage/rated capacity	V/Ah	2x12/75/120
6.4	Battery weight	kg	36
7.1	Noise level at operator's ear, according to DIN12053	dB(A)	<70

Table 1

3 Application

CDD-R walkie pallet stacker adopts storage batteries as the power supply and the AC motor as the driver, traveling by gear transmission. As the traveling and lifting of the truck are electrically driven, it possesses the characteristics of energy saving, high efficiency, stable operation, easy operation, safe and reliable, low noise and no pollution, etc.

Operating environment:

a. Walkie pallet stacker is suitable for indoor hard flat on the ground to use, not suitable for use on the surface of the slope and use on uneven ground. Should not have influence on the ground wheel rolling of convex concave pit and gravel sundry etc.

b. the altitude should be no more than 1200 meters

c. the ambient temperature should be no higher than +40°C and no lower than -25°C

d. When the environment temperature is + 40 °C, relative humidity is not more than 50%, at lower temperature, the larger relative humidity are allowed

e. Not allowed to use in inflammable and explosive or corrosive environments, such as acid-base condition.

4 Operation Instruction

The correct use and operation of the truck will bring great convenience to your work, while incorrect use of vehicles will damage the vehicle and dangerous to the operator.

Before operation, please check whether the truck is under good condition: any leaking for hydraulic lines, any stuck on wheels. Prohibit use the defective trucks.

4.1. Dashboard

There are power switch, key lock, power meter on the dashboard, which are the basic truck control, see Figure 2-1 shows.

4.1.1 power switch: tapping the power off button, at the same time, rotate button closure in clockwise, about 5 ~ 10 degrees, then the button will automatically move up, that is connected to the total truck power supply. Again by closing the button, the power cut off.

4.1.2 key lock: inserted into the power key and turn clockwise about 90 degrees to start the truck; in the opposite way to stop the truck.

4.1.3 power meter: it will display only the power switch and the key switch lock are both opened, it consists of three color indicating lamp display.

a) power meter indicator light shows green: power supply adequacy can be normal use.

b) power meter indicator shows yellow: there is a small amount of power and remind for charging.

c) power meter indicator light shows red: power insufficient please charge immediately!

Safety regulations for Charging the battery

- To charge the battery, the truck must be parked in a closed and properly ventilated room. When charging, the tops of the battery cells must be exposed to provide sufficient ventilation.
- Do not place any metal objects on the battery.
- Before charging, check all cables and plug connections for visible signs of damage.
- Before start and finish charging to make sure power is turn OFF.
- It is essential to follow the safety regulations of the battery and charging station manufacturers.

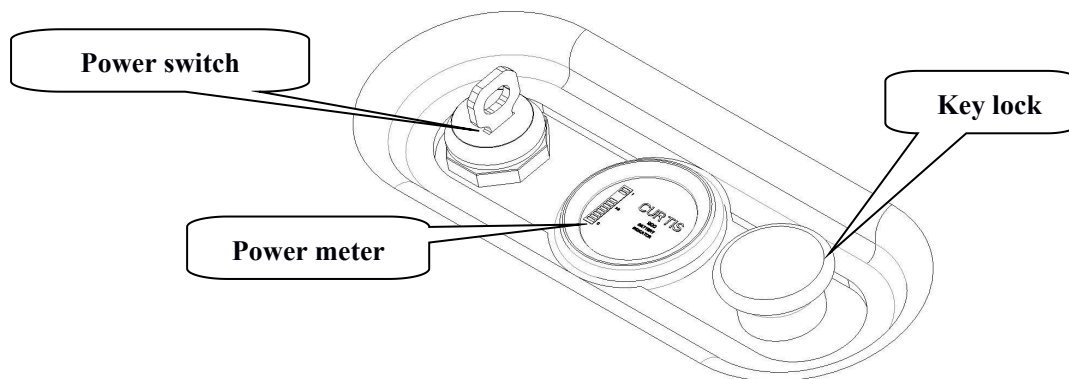

Figure 2-1

4.2. Travel

a. Push forward the speed button, the truck move forward. Speed and angle is proportional. Released the speed button, the truck speed will automatically complex to 0, and the truck will automatically stop.

b. Push backward the speed button, the truck move reverse. Speed and angle is proportional. Released the speed button, the truck speed will automatically complex to 0, and the truck will automatically stop.

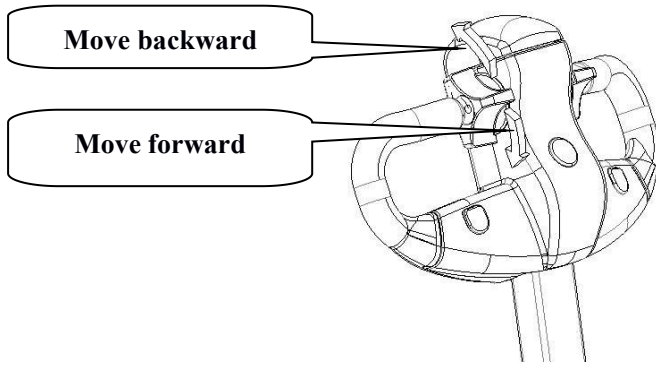

Figure 2-2

4.3 Emergency reverse switch

The red button at the top is the emergency reverse switch, see Figure 2-3.

When touches this switch, the truck will be move in reverse way.

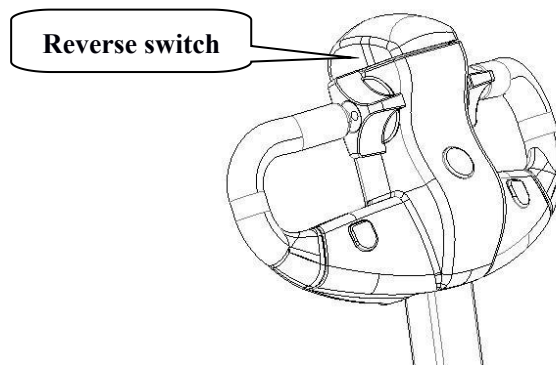

Figure 2-3.

4.4 Lift up and down button, horn button, see details in figure 2-4.

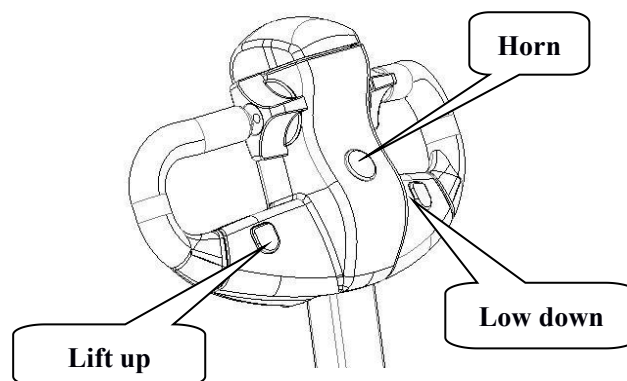

figure 2-4.

4.5 Drive and brake

When the handle is in area A and C, the handle automatic braking ensures.

Set the control handle to the travel range B, and the truck can move in forward or backward.

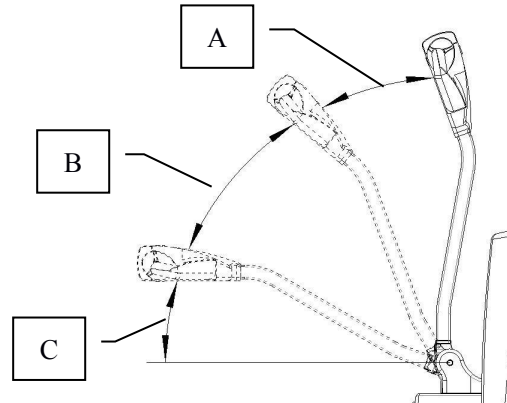

Figure 2-5

4.6 charging socket

a) built-in charger b) external charger

Refer picture as below for external charger:

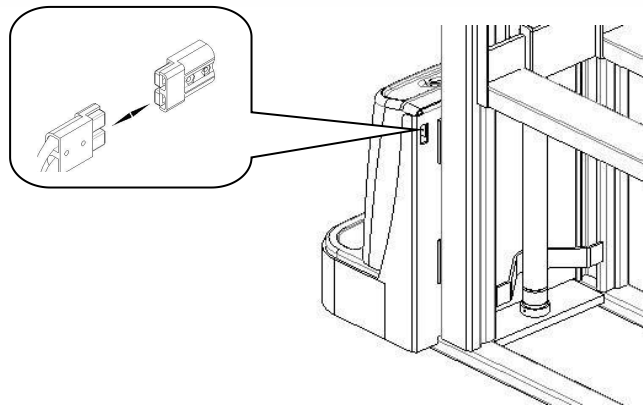

Figure 2-6

5 Maintenance

5.1 Operational safety and environmental protection

– Any modification to the truck assemblies, in particular the safety mechanisms, is prohibited. The operational speeds of the truck must not be changed under any circumstances.

– Only original spare parts have been certified by our quality assurance department. To ensure safe and reliable operation of the for truck, use only the manufacturer's spare parts. Used parts, oils and fuels must be disposed of in accordance with the relevant environmental protection regulations. For oil changes, contact the manufacturer's specialist department.

5.2 Maintenance Safety Regulations

Maintenance personnel

Industrial trucks must only be serviced and maintained by the trained personnel.

The manufacturer's service department has field technicians specially trained for these tasks. We therefore recommend a maintenance contract with the manufacturer's local service centre.

Electrical System

Only suitably trained personnel may operate on the truck's electrical system.

Before working on the electrical system, take all precautionary measures to avoid – electric shocks.

For battery-operated trucks, also de-energise the truck by removing the key.

Settings

When repairing or replacing hydraulic, electric or electronic components or assemblies, always note the truck-specific settings.

Tyres

The quality of tyres affects the stability and performance of the truck. When replacing factory fitted tyres only used original manufacturer's spare parts, as otherwise the data plate specifications will not be kept. When changing wheels and tyres, ensure that the truck does not slew (e.g. when replacing wheels always left and right simultaneously).

Lift chains

Lift chains wear rapidly if not lubricated.

The intervals stated in the service checklist apply to normal duty use. More demanding conditions (dust, temperature) require more regular lubrication.

The prescribed chain spray must be used in accordance with the instructions. Applying grease externally will not provide sufficient

lubrication.

Hydraulic hoses

The hoses must be replaced every six years. When replacing hydraulic components, also replace the hoses in the hydraulic system.

5.3 Servicing and inspection

Thorough and expert servicing is one of the most important requirements for the safe operation of the industrial truck. Failure to perform regular servicing can lead to truck failure and poses a potential hazard to personnel and equipment.

The service intervals stated are based on single shift operation under normal operating conditions. They must be reduced accordingly if the truck is to be used in conditions of extreme dust, temperature fluctuations or multiple shifts.

6. Battery Maintenance

6.1 Safety regulations for handling acid batteries

Park the truck securely before carrying out any work on the batteries.

Maintenance personnel : Batteries may only be charged, serviced or replaced by trained personnel .The present operator manual and the manufacturer 's instructions concerning batteries and charging stations must be observed when carrying out the work.

Fire protection :

- Smoking and naked flames must be avoided when working with batteries.
- Wherever a truck is parked for charging there shall be no inflammable material or operating fluids capable of creating sparks within 2 metres around the truck.
- The area must be well ventilated.
- Fire protection equipment must be provided.

Protection against electric shock:

- Battery has high voltage and energy.
- Do not bring short circuit.
- Do not approach tools to the two poles of the battery, which can cause the sparkle.

6 Possible faults and trouble shooting

No.	Fault	Reason analyze	solution
1	Switch on the power, the power meter no display	The electrical box panel 10A fuse blown or damage of the power switch.	Replace fuse or power switch
2	Can not reach max. lift height	Lack of Hydraulic oil	Add hydraulic oil
3	Hydraulic pump station motor work with noise, pallet fork can not rise or fall.	Electromagnetic valve of the hydraulic pump with dirt jam or stuck.	Remove the valve core, clean with gasoline or kerosene.
4	After open the power switch, with display on power meter, but forks can not lift.	Ascension circuit 175A fuse blown or battery protection controller is damaged.	Replacing the fuse or battery protection controller. Such as broken again, should check whether the circuit is short circuit or device damage.
5	Oil leaking	Sealing / washer damage or failure, nipple joint is loose	Replace with the new seal and tighten joint

Table 2

7 Packaging & transportation

The truck is packed with wooden case. During transportation, turnover and upside-down are not allowed. Collision is not allowed when lifting and loading onto the truck. Do not damage the outward surface of the truck when opening the package

8 Warning (points for attention)

- 7.1 Read the manual carefully before operation and know well the performances of the truck.
- 7.2 It is strictly forbidden to press the lift or lower buttons while the truck is walking and frequently switching the two buttons, which might damage the truck and the goods.
- 7.3 Do not shake the lever rapidly or with high frequency.
- 7.4 It is not allowed to rapidly put heavy goods onto the forks.
- 7.5 The truck should not be overloaded. When overloaded, the truck will not be able to operate normally.
- 7.5 The center of gravity of the goods should be placed between the two forks, otherwise, the forks will be damaged and the goods will fall down in the process of operation.
- 7.6 Loose and unstable goods are not allowed to load onto the truck.
- 7.7 Do not put the goods on the forks for a long period of time.
- 7.8 Turning rapidly on narrow road is strictly forbidden. In order to ensure the safety of the people and goods, the truck should turn slowly in this situation.
- 7.9 When the truck is not in use, the forks should be lowered to the lowest position.
- 7.10 Never put any part of human body under heavy goods and forks.
- 7.11 The truck is applicable for use on plane ground and should never be parked on slope for a long period of time.
- 7.12 Over-load or over-slope operation is strictly forbidden. Otherwise the wheel will slip, damaging the wheel and the motor. The safety of people and goods will be affected as well.
- 7.13 Repairing on one's own before training is forbidden.
- 7.14 Operation of the truck under the stipulated voltage 20.4V is strictly forbidden.
- 7.15 It is strictly forbidden to directly connect the plug with AC power supply for charge except built-in charger.
- 7.16 All interconnecting devices should avoid water.
- 7.17 when the forks lifting more than 500mm, the truck must travel at the lowest speed, and travel can not more than 2m distance.